

SunShades
Transparent Mylar Shades

Phifer
SheerWeave®
BRAND FABRIC

INTERIOR SHADING PRODUCTS

*“CUSTOM MADE”
SHADES IN LESS THAN A WEEK*

“COMPONENTS YOU CAN TRUST”

FABER AND ROLLESE CONTROLS

SOMFY MOTORIZATION

PHIFER SHEERWEAVE, MADICO MYLAR

PANTAFLEX BLACKOUT FABRICS

SUGGESTED PRICING AND POLICY GUIDE

EFFECTIVE JUNE 1, 2017



**MIDWEST MARKETING
DISTRIBUTORS**

2000 E. WAR MEMORIAL DR • PEORIA, IL 61614

PH. 309-688-8858 FAX 309-688-8894

www.midwestmarketinginc.com • Email: jim@midwestmarketinginc.com

ORDERS

1-800-NEU-IDEA

(1-800-638-4332)

CHAIN MECHANISM CONTROLS

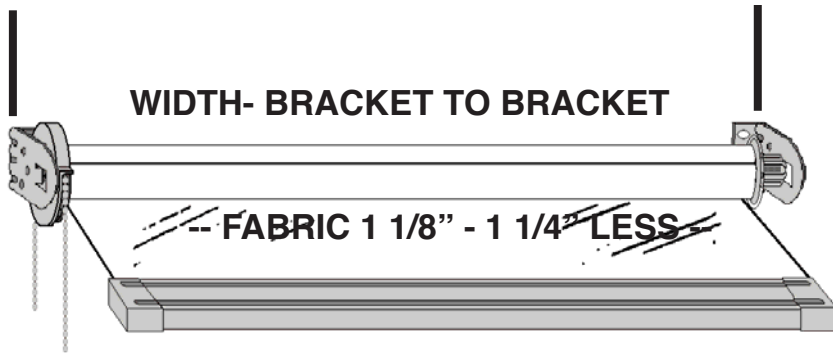

(CM) CHAIN CONTROLS allow an easy and efficient operation and ideal for windows that are hard to reach, floor to ceiling or other large areas that require a heavy duty system. Standard on all Sheer Weave shades.

(RC) ROLLESE CONTROL- See options page for slight upcharge.

SPRING CONTROLS

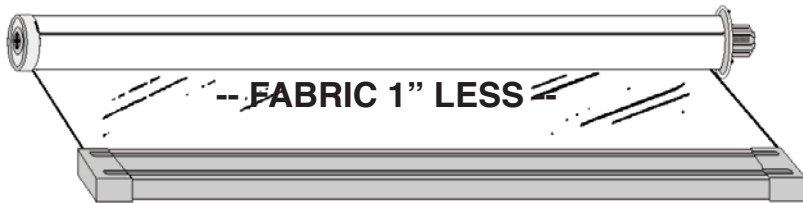

(S) SPRING ROLLERS are a heavy duty trouble free, silent, smooth, ball bearing operation with exact height control.

(M) SOMFY MOTORIZATION AVAILABLE:
Battery Operated, AC and DC powered with Wall Switches, Timers, or Remote Controls. See separate motor pricing.

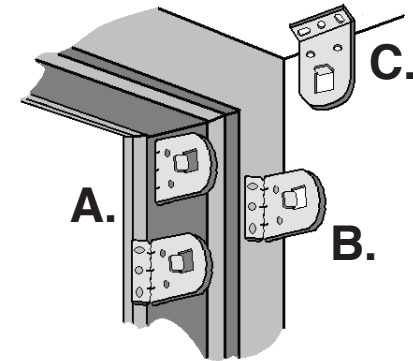

FABER- UNIVERSAL BRACKETS SPRING OR CHAIN CONTROL

A. In jamb B. Outside C. Ceiling

ORDER BY NUMBER

#1- 13/8" Length

#2- 2 3/8" Length

#3- Flat in jamb

#4- Bracket Covers

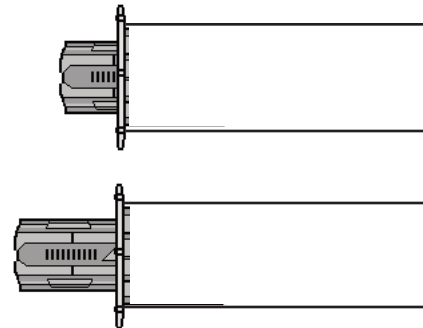

Spring loaded locking
end plug allows 3/8"
automatic adjustment



SUGGESTED RETAIL PRICES TRANSPARENT MYLAR SHADES WIDTH - BRACKET TO BRACKET

Air Traffic
Control
Tower
Shades
and
Hardware
By Quote

WINDOW HEIGHT
DO NOT ADD FOR SAFETY WRAP

	25"	31"	37"	43"	49"	55"	61"	67"	73"	79"	85"	97"	109"	121"	133"	145"
28"	64	72	80	89	96	105	112	121	128	138	154	171	187	204	254	271
34"	71	80	90	101	110	121	130	141	149	161	179	199	220	240	294	314
46"	78	89	101	114	124	137	147	161	170	184	204	228	252	276	333	358
58"	85	98	111	127	138	153	165	180	191	207	230	257	285	312	373	401
70"	92	107	122	139	152	169	182	200	212	230	255	286	317	348	413	444
82"	99	115	132	152	166	185	200	219	233	254	280	315	349	384	452	487
94"	106	124	143	165	180	201	217	239	254	277	305	344	382	420	492	531
106"	113	133	153	177	194	217	235	259	275	300	330	372	414	456	532	574
118"	126	148	170	197	215	240	259	285	303	331	356	401	447	492	571	617
130"	133	157	181	209	229	256	277	305	324	354	381	430	479	528	611	660
142"	140	166	191	222	243	272	294	325	345	377	406	459	512	564	651	704
154"	147	175	202	234	257	288	312	344	366	400	431	487	545	600	691	747

Other
Mylar colors
available:
Amber, Silver,
Gray Silver,
Non-Reflective
Smoke &
5 mil FAA

Child safety chain
tensioner required
for all Residential
shades.

- 1 1/8" Tubes
- 1 3/8" Tubes
- 1 3/4" Tubes

INSIDE HEAVY LINE - Requires a horizontal splice 58" or 70" up from bottom bar.
NOTE: GS35 material will be spliced on shades over 60" H & W

SHADES OVER 105"
CAN NOT BE SHIPPED UPS
NO COD'S BY TRUCK LINE
SEE FREIGHT POLICY

PANTAFLEX

SUGGESTED RETAIL PRICES BLACK-OUT WIDTH - BRACKET TO BRACKET



12 OZ. VINYL
&
FIBERGLASS
MATTE

VIDEO
PROJECTION
SHADES
AVAILABLE
BY QUOTE

WINDOW HEIGHT
DO NOT ADD FOR SAFETY WRAP

	25"	31"	37"	43"	49"	55"	61"	67"	73"	79"	85"	97"	109"	121"	133"	145"
28"	53	59	64	71	76	81	86	91	96	103	116	127	138	149	194	206
34"	56	63	69	78	84	89	95	100	106	114	128	141	154	167	214	227
46"	60	67	74	85	91	98	104	110	116	126	141	155	170	185	233	248
58"	63	72	79	92	99	106	113	120	126	138	153	170	186	203	253	270
70"	66	76	84	99	106	114	121	129	137	149	166	184	202	221	272	291
82"	70	81	89	105	114	122	130	139	147	161	178	198	218	239	292	313
94"	73	85	94	112	121	130	139	148	157	172	191	213	234	256	312	334
106"	77	90	99	119	129	139	148	158	167	184	203	227	251	274	331	355
118"	86	100	111	132	143	154	164	174	185	203	216	241	267	292	351	399
130"	90	105	116	139	150	162	173	184	195	215	228	255	283	310	393	420
142"	93	109	121	146	158	170	181	193	205	226	241	270	299	328	412	442
154"	97	114	126	152	165	178	190	203	215	238	253	284	315	346	433	464

Child safety chain
tensioner required
for all Residential
shades.

-  1 1/8" Tubes
-  1 3/8" Tubes
-  1 3/4" Tubes

 Spring assist has
been added for
Faber controls.

INSIDE HEAVY LINE-SEAM IF OVER 72" W & 58" H - 3/8" HORIZONTAL SPLICE. *NO SEAMING CHARGE.*

*84" Available on white, fawn, beige, solid black or gray.

Large windows can be divided into 2 or 3 shades. They will be lighter, easier to operate,
may not have seams and can usually be shipped UPS instead of truck line.

SHADES OVER 105"
CAN NOT BE SHIPPED UPS
NO COD'S BY TRUCK LINE
SEE FREIGHT POLICY

SUGGESTED RETAIL PRICES SUNTEX 80-90 AND 90 DESIGNER

WIDTH - BRACKET TO BRACKET

ST 80
LISTED
PRICE

ST 90
ADD 5%

ST
DESIGNER
ADD 10%

WINDOW HEIGHT
DO NOT ADD FOR SAFETY WRAP

	25"	31"	37"	43"	49"	55"	61"	67"	73"	79"	85"	97"	109"	121"	133"	145"
28"	70	78	85	94	101	109	118	125	132	142	158	173	192	208	264	281
34"	77	85	94	104	113	122	133	142	150	162	180	197	219	239	298	318
46"	83	93	103	115	125	136	149	159	168	182	201	221	247	270	333	356
58"	89	101	112	126	137	149	164	175	186	202	223	245	275	301	367	393
70"	96	109	121	137	149	163	180	192	204	223	245	269	303	354	401	430
82"	102	116	130	147	161	176	195	209	222	243	266	293	353	385	435	467
94"	109	124	139	158	173	190	211	226	240	263	288	339	381	416	469	540
106"	115	132	148	169	185	203	226	243	258	283	331	363	409	447	539	578
118"	129	148	165	185	205	225	250	268	285	334	353	387	437	532	573	615
130"	136	155	174	195	217	238	266	285	325	354	374	411	518	563	607	652
142"	142	163	183	206	229	261	281	323	343	374	396	435	546	594	641	689
154"	148	171	192	216	241	274	318	340	361	394	417	512	573	624	676	725

Child safety chain
tensioner required
for all Residential
shades.

 1 1/8" Tubes

 1 3/8" Tubes

 1 3/4" Tubes

 Spring assist has
been added for
Faber controls.

All shades are on steel tubes with clutch and bead chain mechanism, springs are not recommended.
INSIDE HEAVY LINE-SUNTEX WILL HAVE 3/8" HORIZONTAL SPLICE IF OVER 96" W. AND 82" H.
SEE OPTION PAGE FOR SLICE PRICING.

SHADES OVER 105"
CAN NOT BE SHIPPED UPS
NO COD'S BY TRUCK LINE
SEE FREIGHT POLICY

SUGGESTED RETAIL PRICES
SW STYLE 2000-2100-7100
WIDTH - BRACKET TO BRACKET

SW 7100
BLACK-OUT
VINYL
LAMINATED
TO SW 2000
ADD 10%

WINDOW HEIGHT
DO NOT ADD FOR SAFETY WRAP

	25"	31"	37"	43"	49"	55"	61"	67"	73"	79"	85"	97"	109"	121"	133"	145"
28"	83	96	106	119	129	145	155	165	175	190	210	230	257	281	345	369
34"	94	110	123	139	151	170	183	196	208	227	249	274	307	336	406	435
46"	105	124	139	158	173	196	211	226	240	263	288	317	357	392	466	502
58"	116	138	155	177	194	221	239	256	273	299	326	360	407	447	527	568
70"	127	152	171	197	216	247	267	286	305	335	365	403	457	524	588	634
82"	137	166	187	216	237	272	295	316	337	372	404	446	528	580	649	701
94"	148	180	204	236	259	298	323	347	370	408	443	512	578	635	710	803
106"	159	194	220	255	281	323	341	377	402	444	503	555	628	690	807	870
118"	178	211	244	282	310	357	387	415	443	511	542	598	678	799	868	936
130"	188	224	260	302	332	382	415	446	498	548	581	641	781	855	929	1003
142"	199	238	276	321	354	408	443	498	530	584	620	684	831	910	990	1069
154"	210	252	293	340	375	434	492	528	562	563	659	780	881	966	1051	1136

Child safety chain tensioner required for all Residential shades.

All Sheerweave fabric edges are cut and heat sealed with an ultra sonic cutter that reduces edge fraying.

Occasional tracking, edge fraying and bottom bar adjustments may have to be made on the job. See blue instruction sheet.

- 1 1/8" Tubes
- 1 3/8" Tubes
- 1 3/4" Tubes

Spring assist has been added for Faber controls.

All shades are on steel tubes with clutch and bead chain mechanism, unless springs are specified.
 *126" AVAILABLE ON LIMITED COLORS OF SW2000.
 INSIDE HEAVY LINE-SEAM IF OVER 96" W & 82" H - 3/8" HORIZONTAL SPLICE. SEE OPTION PAGE FOR SLICE PRICING.
 Large windows can be divided into 2 or 3 shades. They will be lighter, easier to operate, may not have seams and can usually be shipped UPS instead of truck line.

SHADES OVER 105"
CAN NOT BE SHIPPED UPS
NO COD'S BY TRUCK LINE
SEE FREIGHT POLICY

SUGGESTED RETAIL PRICES
SW STYLE 3000

WIDTH - BRACKET TO BRACKET

Fabric Pattern
Reversed or "Railroaded"

WINDOW HEIGHT
DO NOT ADD FOR SAFETY WRAP

	25"	31"	37"	43"	49"	55"	61"	67"	73"	79"	85"	97"	109"	121"	133"	145"
28"	76	87	96	106	115	128	137	145	154	166	184	202	224	244	304	324
34"	85	98	108	122	132	147	158	169	179	194	214	235	263	287	351	376
46"	93	109	121	137	149	167	180	192	204	223	245	269	302	330	399	428
58"	101	120	133	152	165	187	202	216	229	251	275	302	340	373	446	479
70"	110	131	146	167	182	207	223	239	255	279	305	336	379	438	493	531
82"	118	141	159	182	199	227	245	263	280	307	335	370	440	481	541	583
94"	127	152	171	197	216	247	267	286	305	335	365	425	479	524	588	670
106"	135	163	184	212	233	266	288	310	330	364	417	459	517	567	672	722
118"	151	182	204	235	258	295	319	342	364	423	447	492	556	664	719	774
130"	160	192	217	250	274	314	340	365	411	451	477	526	648	707	766	825
142"	168	203	230	265	291	334	362	411	436	479	508	560	687	750	814	877
154"	176	214	243	280	308	353	405	434	462	508	539	646	726	793	862	929

All Sheerweave fabric edges are cut and heat sealed with an ultra sonic cutter that reduces edge fray.

Occasional tracking, edge fraying and bottom bar adjustments may have to be made on the job. See blue instruction sheet.

Child safety chain tensioner required on all Residential shades.

- 1 1/8" Tubes
- 1 3/8" Tubes
- 1 3/4" Tubes

Spring assist has been added for Faber controls.

All shades are on steel tubes with clutch and bead chain mechanism, unless springs are specified.
INSIDE HEAVY LINE-SEAM IF OVER 96" W & 82" H - 3/8" HORIZONTAL SPLICE. SEE OPTION PAGE FOR SLICE PRICING.
 Large windows can be divided into 2 or 3 shades. They will be lighter, easier to operate may not have seams and can usually be shipped UPS instead of truck line.

SHADES OVER 105"
 CAN NOT BE SHIPPED UPS
 NO COD'S BY TRUCK LINE
 SEE FREIGHT POLICY



SUGGESTED RETAIL PRICES
SW STYLE 4000-4100-4400-4800
2390--2360-2410-2500
WIDTH - BRACKET TO BRACKET

SW 4400
 SW 4800
 SW 2410
 SW 2500
 ADD 5%
 TO PRICE

WINDOW HEIGHT
 DO NOT ADD FOR SAFETY WRAP

	25"	31"	37"	43"	49"	55"	61"	67"	73"	79"	85"	97"	109"	121"	133"	145"
28"	86	96	109	120	132	145	155	170	181	192	211	235	262	286	351	375
34"	97	110	126	139	154	170	183	202	215	229	250	279	314	344	414	444
46"	109	124	144	159	176	196	211	233	250	266	289	324	365	423	477	513
58"	120	138	161	178	199	221	239	265	284	303	328	369	439	480	539	581
70"	132	152	178	198	221	247	267	297	318	340	367	435	490	537	602	686
82"	143	166	195	217	243	272	295	328	353	407	428	480	542	594	701	755
94"	155	180	212	237	266	298	323	360	418	444	467	525	593	705	764	823
106"	166	194	229	257	288	323	350	422	452	481	506	569	698	762	827	892
118"	186	216	255	284	318	357	409	454	487	518	546	667	749	820	890	960
130"	197	230	272	304	341	405	437	486	521	555	585	711	801	877	953	1029
142"	209	244	289	323	363	430	465	518	555	592	676	756	852	934	1016	1098
154"	220	258	306	343	407	455	492	550	590	680	715	800	902	992	1079	1167

Child safety chain tensioner required on all Residential shades.

All Sheerweave fabric edges are cut and heat sealed with an ultra sonic cutter that reduces edge fray.

Occasional tracking, edge fraying and bottom bar adjustments may have to be made on the job.

*

- 1 1/8" Tubes
- 1 3/8" Tubes
- 1 3/4" Tubes

Spring assist has been added for Faber controls.

All shades are on steel tubes with clutch and bead chain mechanism, unless springs are specified.
 INSIDE HEAVY LINE-SEAM IF OVER 96" W & 82" H - 3/8" HORIZONTAL SPLICE. SEE OPTION PAGE FOR SLICE PRICING.
 *126" Available on limited colors of 4000 and 4400. Large windows can be divided into 2 or 3 shades. They will be lighter, easier to operate, may not have seams and can usually be shipped UPS instead of truck line.

SHADES OVER 105"
 CAN NOT BE SHIPPED UPS
 NO COD'S BY TRUCK LINE
 SEE FREIGHT POLICY

SUGGESTED RETAIL PRICES SW STYLE 5000

WIDTH - BRACKET TO BRACKET

Inside Dotted Line Material "Railroad"
Check for acceptable pattern.

WINDOW HEIGHT
DO NOT ADD FOR SAFETY WRAP



	25"	31"	37"	43"	49"	55"	61"	67"	73"	79"	85"	97"	109"	121"	133"	145"
28"	87	100	111	125	136	152	163	174	185	201	222	243	272	298	363	389
34"	99	116	129	146	160	180	194	208	221	241	264	291	327	358	430	462
46"	110	131	147	168	183	208	225	241	256	281	307	338	382	419	497	535
58"	122	147	165	189	207	236	256	274	292	321	350	386	437	480	564	608
70"	134	162	183	210	231	264	286	307	328	361	392	434	491	563	631	681
82"	146	177	200	232	255	293	317	341	363	401	435	481	568	624	698	754
94"	158	193	218	253	278	321	348	374	399	441	477	551	623	685	765	863
106"	170	208	236	274	302	349	378	407	435	481	542	598	678	746	868	936
118"	189	231	262	304	334	385	417	449	479	551	585	646	733	860	935	1009
130"	201	246	280	325	358	413	448	482	537	591	627	693	841	921	1002	1082
142"	213	262	297	346	382	441	479	537	572	631	670	741	895	982	1069	1155
154"	225	277	315	367	405	468	532	570	608	671	712	841	949	1043	1136	1228

All Sheerweave fabric edges are cut and heat sealed with an ultra sonic cutter that reduces edge fraying.

Occasional tracking, edge fraying and bottom bar adjustments may have to be made on the job.

Child safety chain tensioner required on all Residential shades.

SW 5000 - Not recommended to railroad, edges may curl. Check for acceptable pattern change

-  1 1/8" Tubes
-  1 3/8" Tubes
-  1 3/4" Tubes

All shades are on steel tubes with clutch and bead chain mechanism, unless springs are specified.
INSIDE HEAVY LINE-SEAM IF OVER 98" W & 82" H - 3/8" HORIZONTAL SPLICE. SEE OPTION PAGE FOR SLICE PRICING.
Large windows can be divided into 2 or 3 shades. They will be lighter, easier to operate, may not have seams and usually can then be shipped UPS instead of truck line.

SHADES OVER 105"
CAN NOT BE SHIPPED UPS
NO COD'S BY TRUCK LINE
SEE FREIGHT POLICY

 Spring assist has been added for Faber controls.

ORDERING

Due to our quick delivery and immediate processing of orders, changes and cancellations are impossible. We recommend that you have a signed contract and deposit from your customer, before ordering. These shades are custom made to your specifications and cannot be returned.

ALL SHADES ARE SHIPPED ASSEMBLED WITH MOUNTING
HARDWARE AND READY FOR EASY INSTALLATION

MEASURING AND ORDERING

Determine where and what type brackets are to be used (inside or outside of frame). Examine your window and immediate area for obstructions that would interfere with installation or operation including; bracket installation (wood, metal, plaster, block, etc.), drapery or shade hardware, cranks, posts, lights, signs, etc.

When using a retractable metal tape, do not bend at a 90° then read. Keep it flat. Do not use cloth tapes or yard sticks. **Measure width at top where brackets are to be installed. Measure each window even though they may all appear to be the same.** (Cut down charge \$20 plus freight)

How To Order We require the use of our free order forms for e-mail or fax. When ordering by phone, review and have all specifications ready from our order forms. **Your order will be read back to you. Listen carefully for correct information. We will not be responsible for mistakes by phone. Do not send confirmation.**

MEASURING AND ORDERING

1. WIDTH - BRACKET TO BRACKET

LINE A-INSIDE MOUNT – Give exact opening size then specify inside. **We will make deductions (1/8").**

LINE B - OUTSIDE OR CEILING MOUNT -

Give an exact measurement of finished shade. A 1" to 2" overlap is recommended on each side.

Material will be about 1 1/4" less than tip to tip width, depending on roller system used or 1 1/4"-2" depending on motor style.

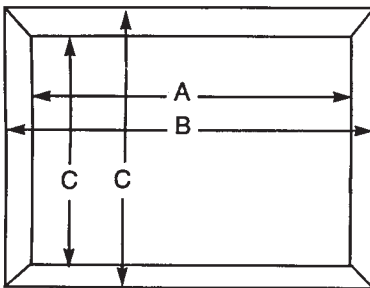

2. HEIGHT

LINE C- Actual window height or shade drop length must be accurate, round off to even inch. We will add for required safety wrap around the steel roller, based on the height supplied. Without proper safety wrap the fabric can detach from the roller tube. This will not be covered by warranty.

Chain stops available for shades not resting on a sill or floor. Must be ordered, no charge.

3. TYPE OF ROLLER

All tubes are 1 1/8"-1 3/8" or 1 3/4" baked enamel steel.

(S) Spring

(CM) Chain Mechanism-Faber (std)

(RC) Rollease add \$2-1 1/8", \$4-1 3/8"

(M) Motors

1. Specify right or left control (facing glass from inside)
2. Color of Chain and mechanism: White-Gray-Brown-Black-Almond-Metal
3. Chain length will be 1/2 the height of shade unless you specify more.
4. Child safety chain tensioner required on all residential shades.
5. Chain Weights-optional

4. BOTTOM HEM

S. STEEL HEM BOTTOM BAR

BLACK (BL) WHITE (W) BRONZE (BR)

HP. HEAT SEALED HEM POCKET (HP) ON SHEER WEAVE AND BLACK OUT.

D. ALUMINUM OVAL DECO BAR (6 COLORS) (UPCHARGE)

5. SHADE MATERIAL

SUNSHADES (MYLAR)

GSG-10 Gray-Silver Gray - 10% VLT

BSB-10 Bronze-Silver-Bronze - 10% VLT

GS-35 Lt. Gray-Silver 35% VLT

Amber, silver, gray/silver and N.R. Smoke and FAA/ATC fabric also available.

SHEERWEAVE STYLE-STOCK

SW 1000 - 30% open - 2 colors

SW 2000 - 5% open - 10 colors

SW 2390 - 5% open - 9 colors

SW 2410 - 3% open - 9 colors

SW 3000 - 14% open - 13 colors

SW 4100 - 10% open - 9 colors

SW 4800 - 1% open - 12 colors

SW 7000 Black Out - 8 colors

Suntex - 80 or 90 - 5 colors

SW 2100 - 10% open - 10 colors

SW 2360 - 10% open - 9 colors

SW 2500 - 1% open - 9 colors

SW 4000 - 5% open - 9 colors

SW 4400 - 3% open - 9 colors

SW 5000 varies 3-10% - 40 colors

SW 7100 Black Out - 6 colors

BLACK OUT PANTAFLEX. - 14 colors

SHEERWEAVE-SPECIAL ORDER - CONTRACT QUOTES OVER \$2000

SW 2701 - 2703 - 2705 - 2710

SW 4500 - 4550 - 4600 - 4650

SW 4700 - 8000 - INFINITY

PERFORMANCE PLUS 2390 - 2410

ALL SHEERWEAVE SHADES ARE TESTED AND ADJUSTED AT OUR FACILITY. SHADES OVER 15' HIGH, OR 12' WIDE OR ANY A.C. MOTOR CANNOT BE TESTED OR TRAINED BY US. THIS IS EASILY DONE ON THE JOB SITE, REFER TO BLUE INSTRUCTION SHEET TO MAKE ADJUSTMENTS.

SW FABRIC OVER 100" WIDE OR HIGH MAY HAVE A MINOR FABRIC DEFECT.

6. BRACKETS Faber spring or chain roller brackets are universal, left-right-ceiling-outside-injamb or extended injamb. Available length 1 3/8" or 2 3/8" length.

PRICES EFFECTIVE – JUNE 1, 2017

Prices subject to change without notice. Check for current prices if over 2 years old.

SHIPPING & FREIGHT POLICY

FREIGHT PREPAID

- UPS on shade orders over \$1500 and under 98" in length
- UPS with shades 98"-105" in length and over \$2000
- Truck orders due to the weight, length or quality and over \$2000

Pre-paid value is for shades only. Accessory values are excluded; motors, fascia, cassette, etc.

FREIGHT PREPAY AND BILL BACK

UPS orders under \$1500 value and shades under 98" in length

- First Shade \$7.50
- Each additional shade \$4.50 each
- Shades with fascia add \$2.00 each
cassette or valance
- Shades with 110v motors add \$4.00 each

FREIGHT COLLECT

(COD'S OR PREPAY AND BILL BACK)

- UPS orders under \$1500 but over 98" in length

UPS policy is any box over 98" at any weight will automatically be charged at 90 lbs. plus a \$50.00 over size charge.

- Truck orders under \$2000 but too long for

UPS

Truck orders not meeting prepaid requirements will be sent freight collect using our 70% out-bound discount.

Minimum freight charge is \$125-\$150. (price based 2011)

Shades on truck orders must be pre-paid, approved net or credit card. We do not ship COD by truck line.

RETURNS OR DEFECTS

Any shade not fitting or with a possible defect MUST be returned to us for repair or replacement (manufacturers discretion). DO NOT LEAVE SHADE WITH CUSTOMER IF IT NEEDS TO BE REPAIRED OR REPLACED. Replacement shades will be sent at a charge if original is not returned, then no credit given. Temporary inexpensive Redi-Shades can be installed if customer needs protection. No changes can be made for replacement orders. Credit will not be given if dealer or customer cancels the order for any reason after shades are made.

RETURN AUTHORIZATION NUMBERS

We will not accept returned merchandise without a prior return authorization (RA) number. Returns from measuring mistakes, phone order mistakes, order changes or cancellation will not be accepted for credit. Remakes and cut downs by quote.

BENT TUBES

If a shade is tight between jams or mullions, that can flex or bow a tube and cause a wobble appearance when operating. That tube needs to be reduced in width. If the tube is truly bent, it did not leave our facility damaged. It may have been bent during shipping or installation. In some cases that tube can be straightened on the job, call for assistance. On truck shipments, we will send you a new tube to replace, all others may be returned for repair.

TERMS

C.O.D./UPS unless otherwise arranged. Credit cards, Visa, MasterCard and Discover are accepted. Net 30 on pre-approved credit.

WARRANTY

Lifetime of all FABER and ROLLEASE components, 10 years on all Phifer SheerWeave material, 5 years on all Pantaflex Black Out, 2 years on all Madico Sun-Shade, 5 years on all Somfy electric motors, 1 year on all remotes and electronics. No warranty on battery packs,

Slight edge curl is a characteristic of Mylar shades and may be seen occasionally. Gradual color change (fading) may also take place and should be expected.

We cannot assume responsibility for minor imperfections in any fabrics. Small Fabric defects may be present in shades over 100". There also may be a small variance in color from roll to roll. SheerWeave may require minor adjustment on the job. Refer to note on SW price list. Warranty covers repair or replacement of the materials only and that choice is at manufacturers discretion. Mileage and labor for removal and/or replacement is not covered. Original shade has to be returned for repair or replacement. Warranty does not cover vandalism or misuse. Fabric may not hang as flat on thinner materials or larger shades.